

Determining and Developing TCM-Live Future Training Requirements

COL Jeffrey Hill
TCM-Live
Fort Eustis, VA
June 2010

The Charter of the TCM-Live

➤ From TCM-Live Charter (Sep 08) ... perform as the Army's centralized manager for combat development and user activities associated with live training systems.

- live fire ranges,
- targets,
- combat training centers,
- home station
- MOUT instrumentation systems,
- tactical engagement simulations, and
- relevant opposing forces systems that support the live training environment.

TCM-Live is the chief architect for the design, development, and sustainment of live training components and interfaces of live training systems.

➤ From TRADOC SYSTEM MANAGEMENT TR 71-12 (Mar 02) ...

Training. Coordinate development of home station and institutional training for individual, crew and unit. Coordinate development and fielding of training aids, devices (system and non-system), simulations and simulators for use in training in the institution, home station, and Combat Training Centers.

Materiel. Coordinate TRADOC position on system reviews, ensure requirement documents are updated as needed, ensure DTLOMS and the logistics support system are in place for system testing and first unit equipped, and plan for system product improvements and recapitalization.

Provide user representation in analysis of alternatives (AoAs), and other studies, evaluations, and efforts supporting the development programs.

Fundamental Premise of Live Training

- Live is default standard of training environments or modes. Everything, with the exception of some tasks trumped by safety considerations, can be trained live. Having Soldiers train on actual equipment in real-time, within an accurately portrayed Operational Environment, against a proportioned, hybrid enemy capable of taxing the unit to execute desired tasks, is preferable to any other mode of training.

The Training Requirements Bridge

The preferred method

Live Training

Untrained



Trained &
Ready



We cross the bridge from untrained to trained, Reset to Deployment, by **live training** of soldiers on the **actual equipment** in as closely **approximated operational environment** as possible.

The Training Requirements Bridge

However

Untrained



Trained &
Ready



... the Gremlins of safety, environmental damage and OPTEMPO emerge and take huge bites out of our live training bridge.

Key Supporting Idea

- Live training identifies “gaps” in the capability to train some tasks live (perhaps based upon time, money, environment, safety, etc.).
- Having identified those live training “gaps,” the virtual, constructive and gaming community at the direction of CAC-T (in concert with the proponents and ACOMs) does the research, training media analysis, and cost-benefit analysis needed to identify a solution set to filling the “gaps” in live training.

Capabilities-based Analysis (CBA) leads to requirements!

The Training Requirements Bridge



So the virtual, constructive, gaming and distance learning TCMs help us find the patches needed to cross the chasm

Programs for Now and Tomorrow

- Now ...
 - I-MILES
 - Instrumented Ranges
 - CACTF
- Tomorrow ...
 - NLOS tactical engagement adjudication
 - New generation of targeting
 - CACTF w/virtual targetry and position/location

An Illustrative Briefing – Live TSS Requirements Convergence Roadmap

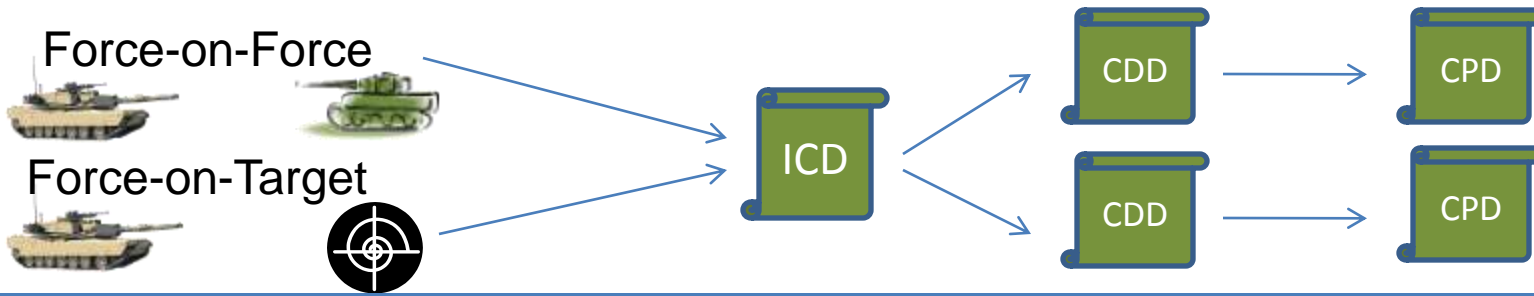

2010 2011 2012 2013 2014 2015 2016 2017 2018

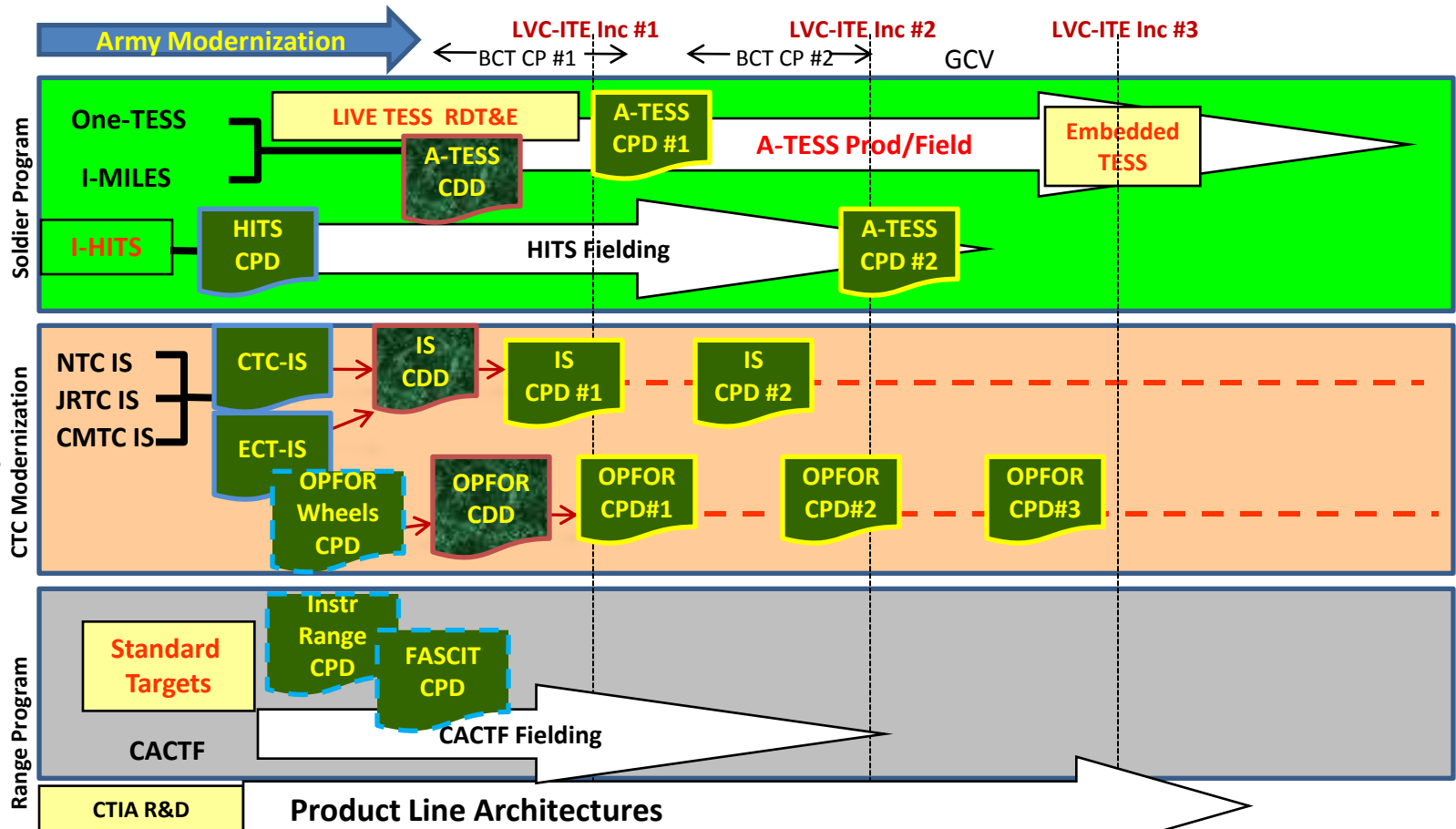

Live Training Transformation
Family of Training Systems
(LT2-FTS) ICD

Summary

- TCM-Live is the combat developer for Army live training
- Requirements are based upon Proponent and ACOM input
- New requirements must pass the rigor of a Capabilities-based Analysis (CBA)