



U.S. AIR FORCE

12 Sept 2010

**USAF Liaison
Report**

Michael Frey

AGENDA

- Near-Term ATE opportunities/Contract Vehicles **
- Logistics Transformation/USAF RE21 Status
 - ASD-WR Reorganization Under GLSC (High Level Look)
- USAF ATS updates and Vision **

- News
 - 2011 Budget AF Spending Plan
 - 2012 Budget Outlook and beyond
 - Top 5 AF programs
 - AF AC news

Near-Term ATE opportunities/Contract vehicles

■ B-1B ARTS REW Replacement

- RFI issued
 - RFI contained Product Description, Statement of Work, and questions for Industry
- Industry Day TBD
- Question of Performance Based Spec still TBD
- Total package Hardware and software

■ WR Small Business Acquisition & Sustainment Tool (SbAST) (WR Only)

- SB contract NAICS 336411 1500
- 5 yr IDIQ 3 basic +2 year options
- \$402M IDIQ
- 5 Contract awards
- Award by end of CY 2010

■ Hill AFB DESPIII RFI

- IDIQ Eng, Tech, Support Services
- Can be utilized by ALL DoD agencies
- OSD review
- RFP Responses 19 July, Award CY 2011

Logistics Transformation - News

- **GLSC** and **ECSS** the new enterprise system for improving over-all Supply Chain Management.
 - New **AFMC/ALC** realignment under **GLSC** completed 1 July
 - New organization charts for each **ALC**

- **ECSS** will enable a single data entry for Logistics info. (Will replace over 240 existing Mx and Logistics databases)
 - Pilot roll out in 2010 Hanscom AFB, 12-18 Month pilot with FOC planned 2014
 - Seimens “**Team Center**” Key software tool for managing Tech Data and Data Management.
 - Other services will be linked via a common commercial software called “**SCORE**”
 - First ECSS sites Ellsworth AFB (B-1B) and Gunter AFB

- **RE 21 Repair Enterprise (Regional Repair Centers and ALC - field to depot repair support)**.
 - Ultimately USAF to stand up (10) CONUS CIRFs (5) Active, (1) ANG and (4) Integrated
 - Repair Network Integration (RNI) (delayed ~ 1 year)
 - Phased Implementation for Commodities and Weapons Systems
 - Multi-year journey- Working Enterprise Management activities and Standardization processes first
 - Shape and size Network next (CRFs)

***Reorganization
Briefing***

WR-ALC Sustainment Wings

330 ASW

- 345 Programs / Projects
 - 64 Acq Master List Prgms
 - 281 Other Efforts
- \$ 11.4B Executed Annually (US)
- \$2.6B Executed Annually (FMS)
 - 42 FMS Customers
- 3,836 FY09 Contract Actions

542 CSW

- 312 Programs / Projects
 - 19 Acq Master List Prgms
 - 293 Other Efforts
- \$2.6B Executed Annually (US)
- \$.7B Executed Annually (FMS)
 - 34 FMS Customers
- 2,625 FY09 Contract Actions



Why Are We Reorganizing?

Air Force 2008-2010

Strategic Plan

- *Reinvigorate AF Nuclear Enterprise*
- *Win Today's Fight*
- *Develop & Care for Airmen & Families*
- *Modernizing Aging Air & Space Inventories*
- **Recapture Acquisition Excellence**

- **Acquisition Improvement Plan (AIP)**
 1. Revitalize the Air Force acquisition workforce
 2. Improve requirements generation process
 3. Instill budget and financial discipline
 4. Improve Air Force major systems source selections
 5. **Establish clear lines of authority and accountability within acquisition organizations**



Michael B. Donley
Secretary, USAF



Norton A. Schwartz
Chief of Staff, USAF

AFMC/CC Memorandum



DEPARTMENT OF THE AIR FORCE
HEADQUARTERS AIR FORCE MATERIEL COMMAND
WRIGHT-PATTERSON AIR FORCE BASE, OHIO

01 MAY 2009

MEMORANDUM FOR AFGLSC/CC
OC-ALC/CC
OO-ALC/CC
WR-ALC/CC

FROM: AFMC/CC
4375 Chidlaw Road
Wright-Patterson AFB OH 45433-5001

SUBJECT: Combat Sustainment Wings (CSWs) Realignment and Air Force Global Logistics Support Center (AFGLSC) Way Ahead

1. We stood up the AFGLSC on 28 Mar 08 to provide enterprise management of the supply chain. Everyone worked hard to make the initial rollout of this organization a success. After a year of operation, we have determined a need to re-emphasize the original intent and establish a clear and consistent distinction of roles/responsibilities between Air Logistics Centers (ALCs) and AFGLSC.

2. Supply Chain Management is a core function of the AFGLSC. The AFGLSC was designed and resourced to provide this capability. The success of this mission requires the strategic management of item level assets and technical resources (logistics management specialists, equipment specialists, and item level engineers) needed to achieve critical reliability improvements and cost savings.

3. Product support is a core mission of the ALCs and the organizational framework and functional infrastructure is built to support this capability. System Program Manager (SPM), System Support Manager (SSM), and Product Group Manager (PGM) responsibilities will remain aligned to ALCs. SPM, SSM, and PGM responsibilities and associated resources currently residing in the AFGLSC will transition to the ALCs. The AFGLSC will not receive product support mission assignments.

4. In the next few days, the Centers will be tasked to begin reworking the OCR. The HQ staff will provide additional details to define product support, review proposed transfers, resolve standardization issues, and provide final direction.

5. I realize this effort will require significant support from all parties and expect your full cooperation and leadership as we move forward. My lead for this effort will be Mr. Ross Marshall, HQ AFMC/A4, DSN 787-1711, (937) 257-1711, ross.marshall@wpafb.af.mil.

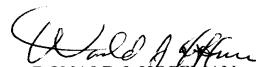
DONALD J. HOFFMAN
General, USAF
Commander

cc:
ASC/CC
AAC/CC
ESC/CC
HQ USAF/A4

War-winning Capabilities...on time, on cost

- AFMC/CC, 1 May 2009 memo directs;

-- Alignment of Supply Chain Management responsibilities to AFGLSC

-- Alignment of Product Support responsibilities to ALCs

Reorganization Actions

FROM

- **Wing (330 ASW / 542 CSW)**
 - **Group**
 - **Squadron**
 - **Flight**

TO

- **Directorate (WR-ALC/GR - *ASD)**
 - **Division**
 - **Branch**
 - **Section**

*Aerospace Sustainment Directorate (ASD)
[PROPOSED]

542 CSW

Reorganization Actions

542d Combat Sustainment Wing

Gaining Org **(FROM)**

- AFGLSC
- WR-ALC/GR
- WR-ALC/EN
- OO-ALC/GH

542 CSW

542 CSW
STAFF OFFICES

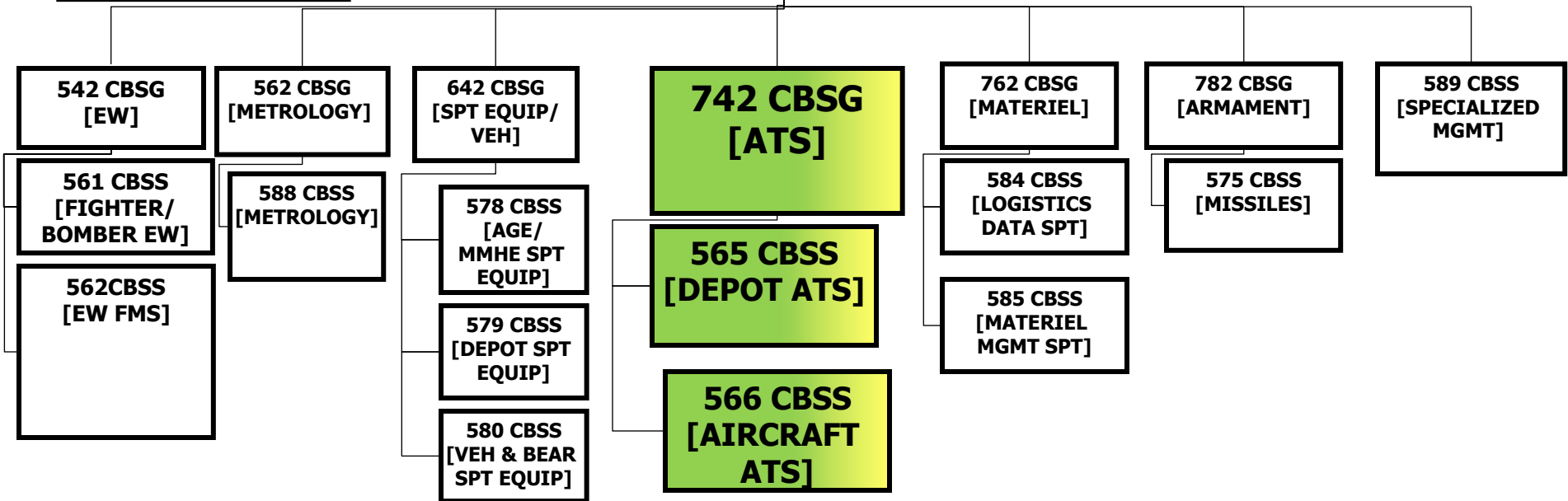

WR-ALC/GR ***Aerospace Sustainment Directorate*** ***(TO)***

**AEROSPACE SUSTAINMENT DIR
WR-ALC/GR**

**ATS DIV
GRN**

**FIELD LEVEL ATS BR
GRNA**

**DEPOT ATS BR
GRNB**

**ENGINEERING BR
GRNE**

**CONTRACTING BR
GRNK**

WR-ALC/GR ***Aerospace Sustainment Directorate*** ***(TO)***

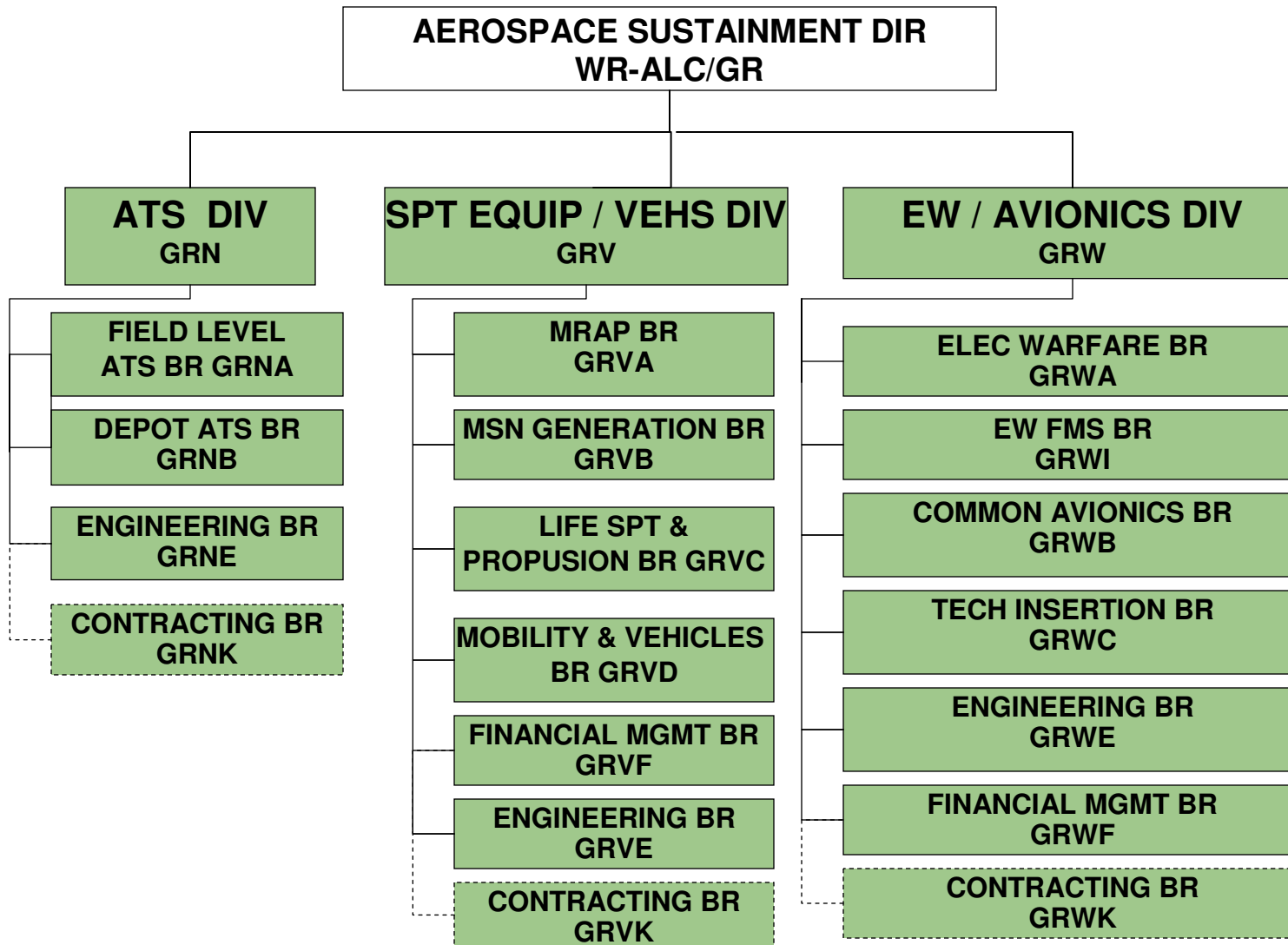

Draft FY 2011 USAF Defense Budget (Highlights)

- FY-11 Defense Budget \$708B Core budget \$548B, \$159B for War efforts
- \$11.0B for (42) F-35
 - AF rejects 2nd Engine Second Engine effort and C-17 additive Gates recommends Veto of second Engine and more C-17s(Congress Providing Money)
- \$4.0B for New Long Range Strike Bomber IR&D (ABSD) (2011-2015)
 - No procurement \$ until after 2020
 - Includes Research for new Cruise Missile
 - Upgrades for B-52 and B-2
 - Enhance Prompt Global Strike
- Increase Purchase of MQ-9 Reapers
- \$6.3B for Special Ops
- \$9.9B for Missile Defense
- \$2.7B for ISR
- \$11.B for Nuclear Enterprise (Billions Promised to enhance and sustain existing Arsenal)
- Unfunded Requirements \$548M (Wartime additives, Depot Mx, B-2, B-1, KC-135, C-5 A-10)
- \$4B being moved around Pentagon Budget for FY10 to accommodate War needs

- DoD Budget Projections for 2012-16 submitted 31 July
 - Possible changes to POM process are in work
- Government panel recommending more use of existing contract vehicles and GSA

- 20 year look ahead
 - Manned Fighters to decline by 10% 2010-2020
 - UAVS to be quadrupled during same period
 - 3% average growth of DoD Budget at risk
 - Aviation Programs 2011-2020 \$268B at risk
- Questions about Recent 2010 QDR effort
 - 20 year force structure or Budget exercise?
 - Congress seeking independent review

Budget News

- **Acquisition Chief met with Industry 28 June:**
 - **Defense Budget growth at 1% rate over next 5 years**
 - **Looking for 3% reduction from current budgets to pay for direct combat efforts**
 - **Asking Industry to come up with cost cutting initiatives to drive down cost of new weapon systems. Ex. LM, Boeing**
 - **Be prepared for smaller Annual budgets**
 - **Two-thirds of dollars from \$100B Gates directive to come from Support Programs i.e. force structure and modernization programs**
 - **~\$16.5B targeted from future Budgets annually**
 - **Fiscal Reality “Flat or declining Budgeting environment”**
 - **Economic conditions driving Future defense spending**
- **Europe already seeing significant cuts in Defense Budgets**

Budget News

- **Pentagon Advisory Panel recommendations**
 - **Final report due in Sept**
 - **Recommendations**
 - **Cut DoD Civilian personnel by 110,000 from 743K Force**
 - **Immediate Hiring freeze**
 - **Reduce redundancy in Military Combat Structure and reduce contractor support by 11,000**
 - **SECDEF Closing US Joint Command, reducing Flag officers/SES**
- **DoD Industrial Affairs**
 - **Desires savings to come from improved Procurement process**
 - **Cuts noted are for New/existing programs/Requirements**
 - **Everything is on the table**
 - **F-35 LRIPs could be impacted**
- **Congressional Sustainment Defense Task Force**
 - **Targeting \$1.1T in DoD Spending cuts over next decade**
- **Gates has already challenged Services to find \$101B in savings next 5 Years**
 - **50K (AF10K) Force cuts and reduce 1-2 FW and close upward of 16 OS bases (\$80B) projected annual savings**
- **Alternate QDR**
 - **Current spending plans and projected cuts not filling future threat environment**
 - **\$101B savings/\$15B per year not enough to meet modernization needs**
 - **Recommendations from Alt QDR run counter to current Admin/Pentagon path**
- **Concerns US Debt and economic issue will be resolved on the back of DoD**

News –Budget and Programs

- Top 5 USAF requirements:
 - **KC-X Tanker Replacement** TOP AF Priority
 - RFP responses submitted 9 July response
 - **Award planned 12 Nov**
 - AF acquisition with “Robust OSD Oversight” “Best Value” FFP
 - 179 AC – First AC to AF 2015 – IOC 2017
 - 15 year build in 5 Lots
 - First flight 2012, first lot FY13, First AF AC delivery 2015
 - KC-Y and KC-Z to follow – To replace remaining KC-135s and KC-10
 - EADS (with US Partners ?)
 - US Aerospace and Ukrainian Antonov bid program AN122/124 (Protest)
 - **CSAR-X** – Back on the table
 - Gates directed Study to determine if Joint potential
 - Looking at Options - CV-22, Others
 - AF to retain a CSAR mission
 - **Satellites for Early Warning/Com** - Refocused
 - **F-35** –Production Number maybe reduced if Cost is not stabilized
 - DoD focusing on cost and schedule growth impact delays in F-35 program.
 - Gates Extends Development/Testing phase to 2015
 - AF version ahead of Test schedule LRIP4 approaching
 - DoD pressing LM for FFP Production
 - LRIP numbers have been reduced and Full rate production delayed until Nov 2015
 - **AF IOC now 2016 (2-3 year extension)**
 - Continued funding for Alt. Engine could reduce number of F-35s (Veto Threat) AF Rejects 2nd Engine
 - All services now looking at extending service life of legacy AC.
 - Congress now pushing for Block 60 F-16s and F-15 Silent Eagles as back-up plan
 - F-35 exceeded 50% Cost growth 1 April (5 other Major DoD programs also)
 - DC Think Tank indicates F-35 quantities could be impacted by increased adversary defense capabilities
 - **NGLRS (ABSD) Airborne Strategic Deterrence (Driven by QDR)**
 - FY11 Budget \$1.9B for R&D of new Bomber
 - No new bomber until after 2020 (Still key element of Nuke Triad of Nuclear Deterrence)
 - Navy and AF developing a new LRS capability
 - DoD now looking at “Family of Systems” concept for LRS EW Attack/ISR, deep penetrating strike
 - Still refining concept Requirements
 - Recent START Treaty could impact how many Bombers remain in Nuclear role
 - Subs & Missiles more survivable and responsive

AF News

- 2012 Budget described as “Ugly”, Future AF budgets look grim. AF Budgets Flat for foreseeable future.
 - Nat’l Debt impacting DoD budgets going forward
 - NATO Defense Budgets heading south due to economy impacts
- More AF tasking versa funds to pay for the bills
- Personnel and facility cuts back on the table
 - 50K (AF10K) Force cuts and reduce 1-2 FW and close upward of 16 OS bases (\$80B) projected annual savings
- Program cuts possible
 - Any gains in capability will be achieved thru divesting of other programs or infrastructure.
- AF Aircraft readiness now lowest in over 20 years
- F-35 program eating over 40% of the AF modernization budget
- AF expected to accept more risk in Mission, but is trying to maintain a more capable smaller CAF
- Major concerns that US Defense Industry talent is disappearing with end of development on F-35
 - No new near-term programs on the horizon
- Army and AF issues

AF News Cont.

AF Realignment Plans

- Legacy AC retired sooner
 - 250 F-16 to be retired within year
 - F-16 Training Wing move to Holloman
 - MQ-1/9 at Holloman
- F-22 Consolidate and redistribute F-22 Wings into 4 Bases
 - Tyndall, Langley, Elmendorf, Nellis
 - AF retaining F-22 Tooling for future sustainment options
- F-35
 - Eglin Initial Pilot/Maintenance Training
 - Luke F-35 follow-on training 2013-2017
 - Hill 2015-2019
 - Burlington 2018
- C-27J Basing still TBD
- MC-12W Beale AFB
- Realign 12K airman to accommodate above.

Aircraft Activity-News

- AF “Technology Horizon” 2030 Study
 - Initial Briefing to AF leadership Feb 2010
 - Themes for 2030 AF
 - Manned versa Unmanned (MAVs)
 - Larger to smaller systems
 - Composable Systems (Adaptable 75-80% solutions systems in weeks versa years) “Modularity”
 - Hypersonic Engines Mach 6+
 - Automated Logistics (to reduce manned involvement)

- Full funding in Budgets for UAVs based on QDR recommendations.
- New USAF X-37B in orbit undergoing tests
- F-15 Silent Eagle first flight in July
- MQ-X Expected RFP by 2014
 - Replacement for Reaper
 - Defining Requirements
- MQ-1/MQ-9 Basing
 - Whiteman IOC Feb 2011
 - Ellsworth IOC May2012
- KQ-X UAV Mid Air Refueling Demo
 - UAV-to UAV Test (Global Hawks)
- AF getting serious about a T-38 Replacement effort
 - AoA by end of the year
- AF celebrates it 63 Birthday 18 Sept



U.S. AIR FORCE
