

PENNSTATE



A Capstone Exposure to the Systems Engineering Process: Students' Experience with the DoD's Pre-positioned Expeditionary Assistance Kits (PEAK) System

**David Wilson, Elizabeth Kisenwether, Robert Capuro, Sven Bilén,
James Nemes***

The Pennsylvania State University

The National Defense Industrial Association has identified a deficit of system engineering expertise needed to meet the demands of government and industry. To expose engineering undergraduate students to the systems engineering field, a focused set of systems engineering projects were offered in Fall 2010 in an undergraduate multidisciplinary capstone course as part of a Department of Defense-funded STEM (science, technology, engineering, and math) initiative. This multidisciplinary engineering capstone design course at The Pennsylvania State University was comprised of students with little or no prior systems engineering exposure from traditional engineering disciplines. Systems engineering was introduced through inclusion of eight systems engineering modules covering systems engineering fundamentals, requirements analysis, systems thinking, systems architecture, problem solving, verification and validation, project management, and decision and risk analysis. The multidisciplinary capstone design course was also restructured to follow a more traditional systems engineering life cycle, going from mission statement, system requirements review, conceptual design review, preliminary design review, and finally, critical design review.

* 30 E. Swedesford Rd, Malvern, PA 19355
610-725-5365, jan16@psu.edu

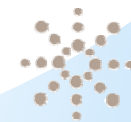

SYSTEMS ENGINEERING
Research Center

A Capstone Exposure to the Systems Engineering Process: Students' Experience with the DoD's Pre-positioned Expeditionary Assistance Kits (PEAK) System

March 2011

The Pennsylvania State University

Email: jan16@psu.edu

Project Objectives

- Address projected shortage of systems engineering expertise by introducing systems engineering into an undergraduate capstone design course.
- Use DoD project as systems domain application for student learning

Systems Application

PEAK is to demonstrate and transition an array of capabilities that can be pre-positioned to help provide sustainable, essential services and improve partner nations' ability to provide critical services and situational awareness during the first days of a crisis event.



Course Objectives

At the end of the course students should

- Understand what systems engineering is
- Understand what systems engineers do
- Understand the qualities and skills that systems engineers bring to projects
- Develop and practice the skills of systems engineers
- Understand how systems engineers think (analytic skills)
- Consider a career in systems engineering

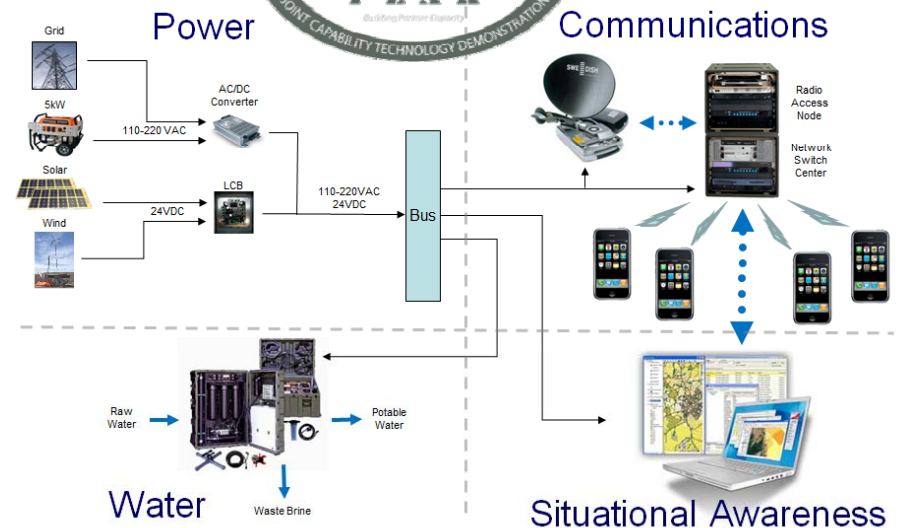

Overview of Systems-Themed Multidisciplinary Design Course

- * Leveraged existing EDSGN 497 Multidisciplinary Design Course
- * Added Systems Engineering Modules
 - * Systems engineering fundamentals, requirements analysis, systems thinking, systems architecture, problem solving, verification and validation, project management, and decision and risk analysis
 - * Taught by faculty at Penn State Great Valley
- * All faculty involved had SysE experience
- * Students divided into four teams, came from different majors
- * Weekly meetings with DoD sponsors

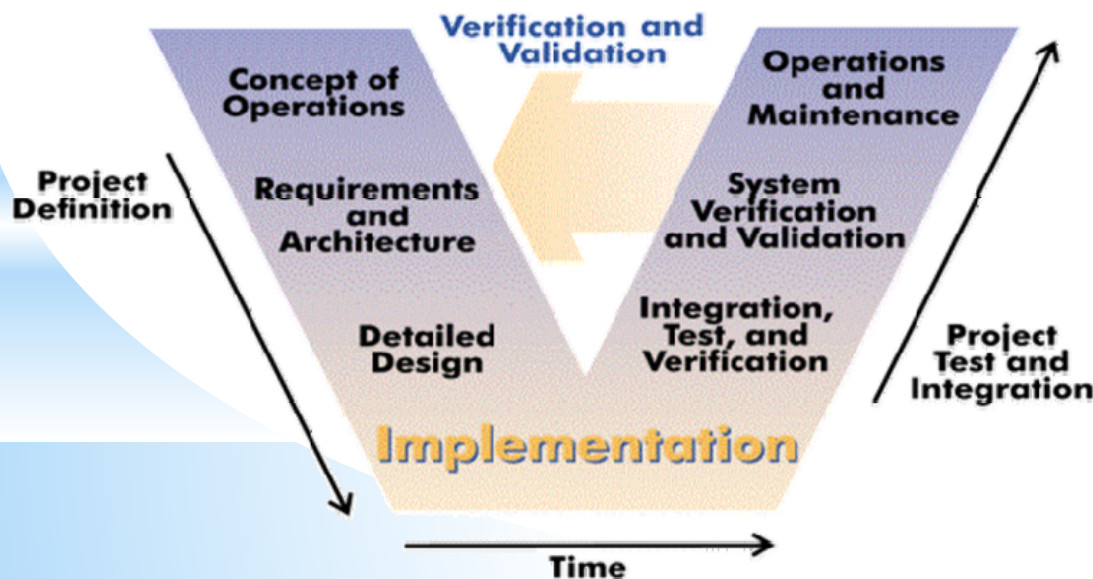

Student deliverables over 14-Week Semester:

Systems Requirement Document
Architecture Design Document
Conceptual Design Review
Verification & Validation Plan
Risk Mitigation Plan
Preliminary Design Review and Report
Critical Design Review and Report
Functioning prototypes for each subsystem

DoD - PEAK (Pre-positioned Expeditionary Assistance Kits) Overview

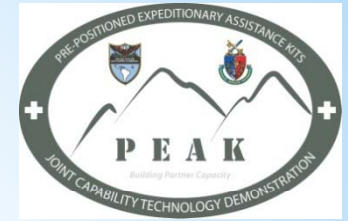

PEAK is to demonstrate and transition an array of capabilities that can be pre-positioned to help provide sustainable, essential services in time sensitive events:

- * Enhance partner nation capabilities to carry out key missions through proactive military-to-military engagement
- * Improve partner nations' ability to provide critical services and situational awareness during the first days of a crisis event
- * Collaboratively enhance regional stability and security



PEAK will deliver the following capabilities:

- * Potable water from local sources
- * Reliable power from primarily renewable sources to power the PEAK components
- * Local situational awareness and information sharing on threats, local populace, services, environment, infrastructure and other personnel
- * Local, regional/national and global communications to transmit & receive voice, data and images



PEAK Water Purification Subsystem

→ *efficiently purify fresh, brackish or salt water into potable water*

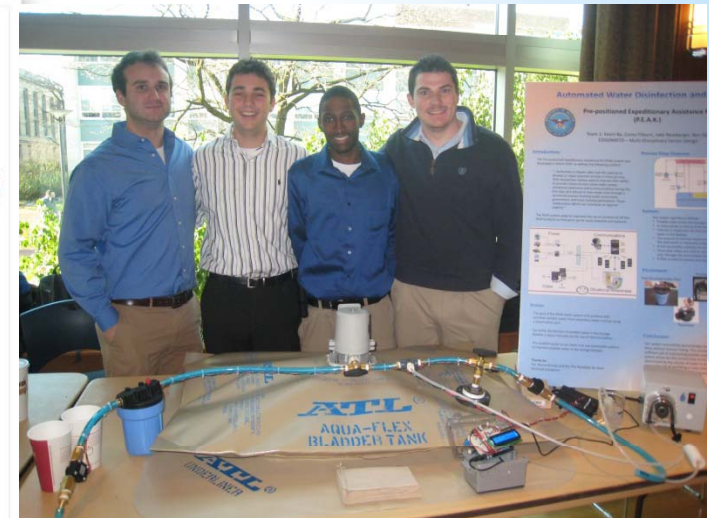
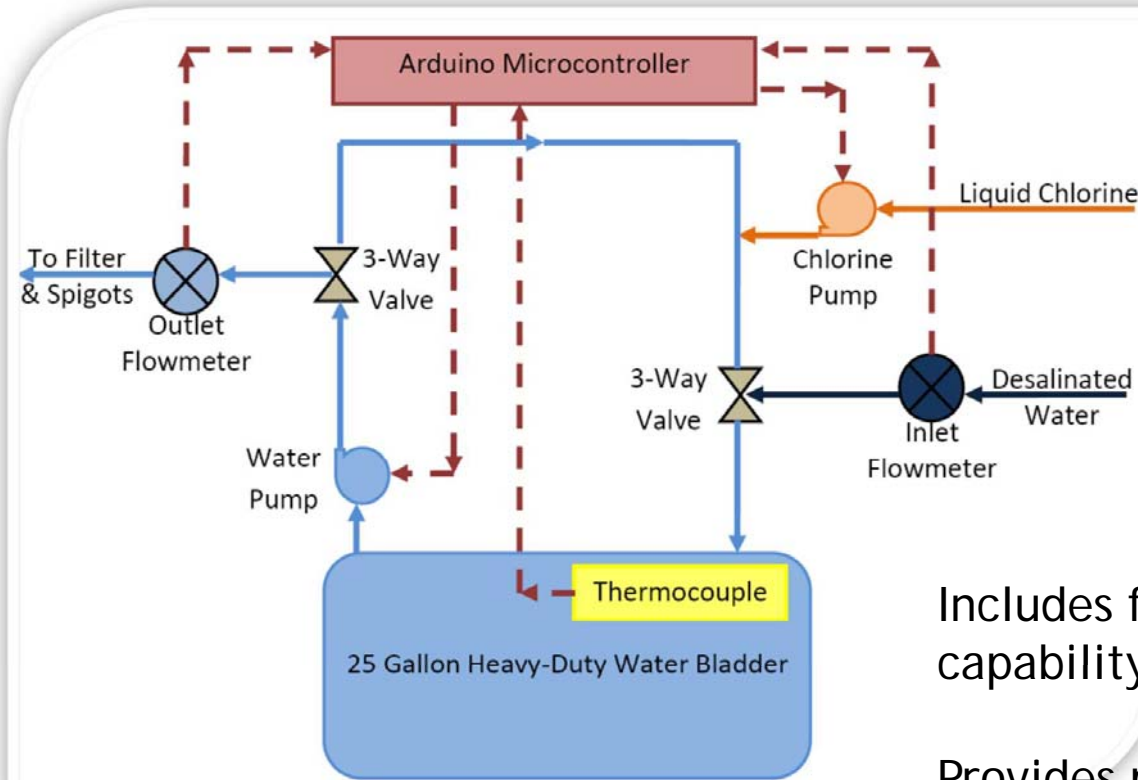

Includes filtration system, distribution capability, and storage container

Provides potable water for drinking and hygiene

Powered through the Power Generation Subsystem

PEAK Power Supply Subsystem

→ *provide all power needs for the PEAK Kit using renewable sources and generator backup*

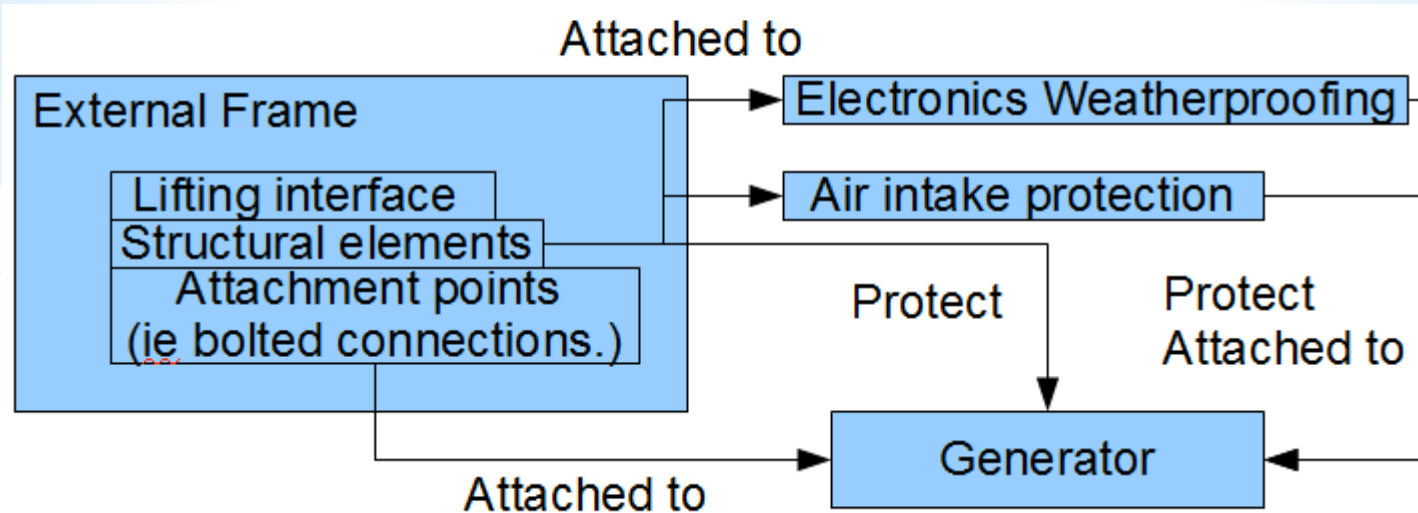

Power is generated through renewable resources (solar, wind, etc.) with a fossil fuel generator backup.

Has sufficient capacity to support all components of the kit simultaneously

PEAK Local Situational Awareness Subsystem

→ provide information on threats, local populace, services, infrastructure

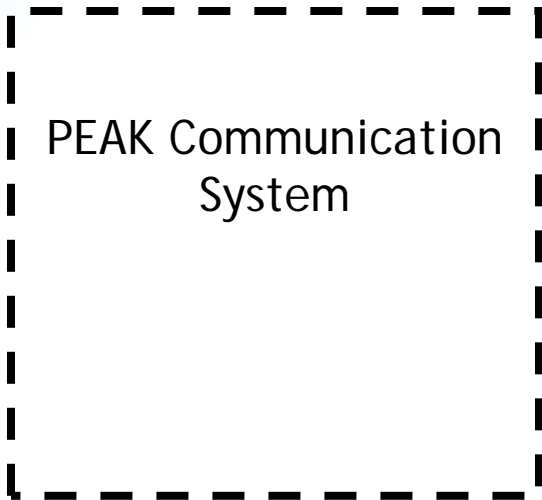

Unmanned Aerial System (UAS), control device, camera (still or motion), and platform to view images.

Integrates with System
Power through the Power Generation Subsystem

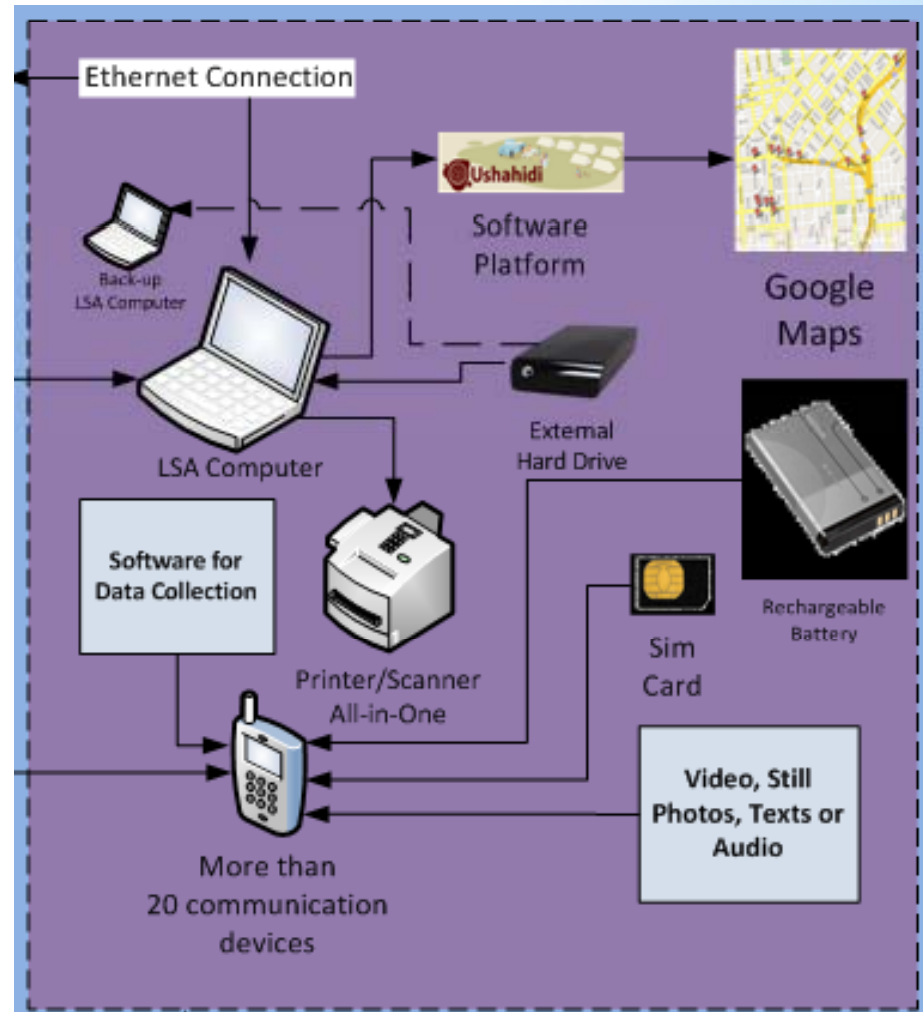

PEAK Communications Subsystem

→ using low-bandwidth, support voice, data and image communications

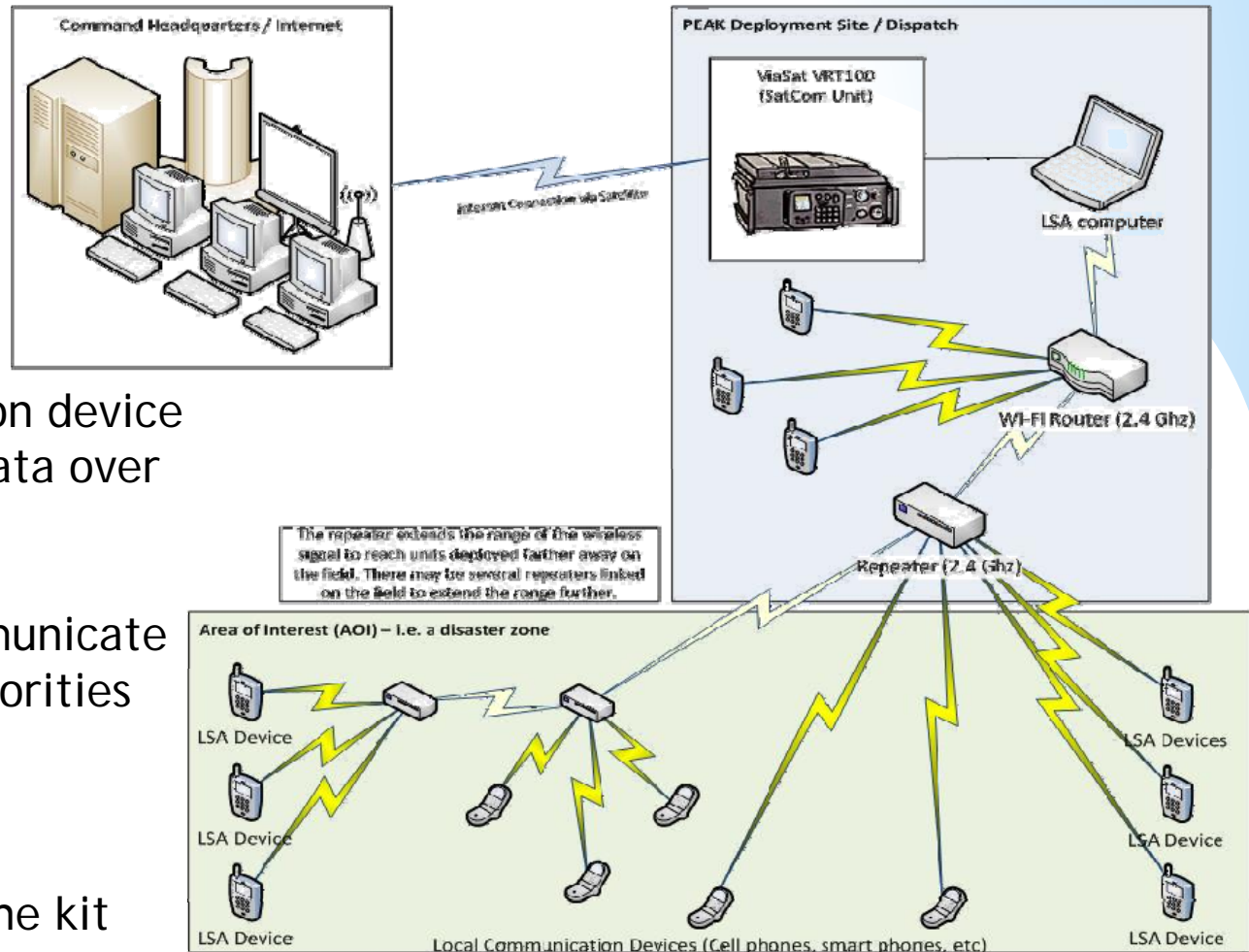

Consists of a communication device that transmits voice and data over a low bandwidth network.

Enables personnel to communicate situation reports with authorities and other aid personnel.

Integrates with situational awareness component of the kit
Powered through the Power Generation Subsystem.

Summary of Educational Impact

System Engineering Knowledge Assessment

A survey was designed to assess general systems engineering knowledge

Survey was administered to the students at two time points: beginning and end of fall 2010 semester

Pre- and post-survey contained the same items such that baseline knowledge could be determined, and the responses could be compared across the two time points, thus allowing for the evaluation of potential systems engineering knowledge changes

Pre- and post-survey served as summative assessment of the students' systems engineering knowledge



Two teams win Boeing Systems Design Award at Showcase

Exposing undergraduate students in the more traditional engineering fields to systems engineering fundamentals, and allowing them to apply those fundamentals in a course such as the SE Capstone, is an effective method to provide exposure to and an appreciation of systems engineering principles